

4

3

2

1

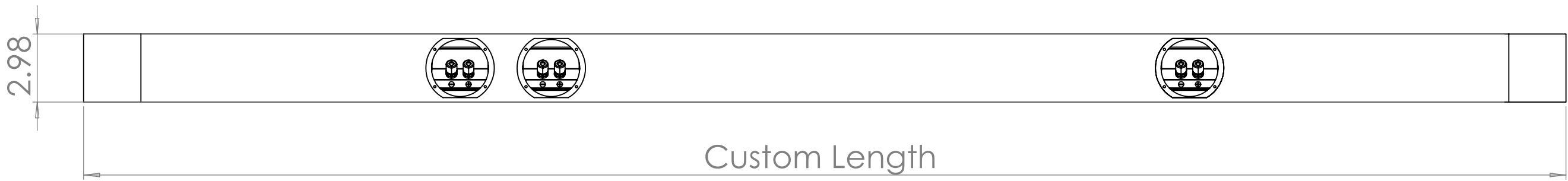
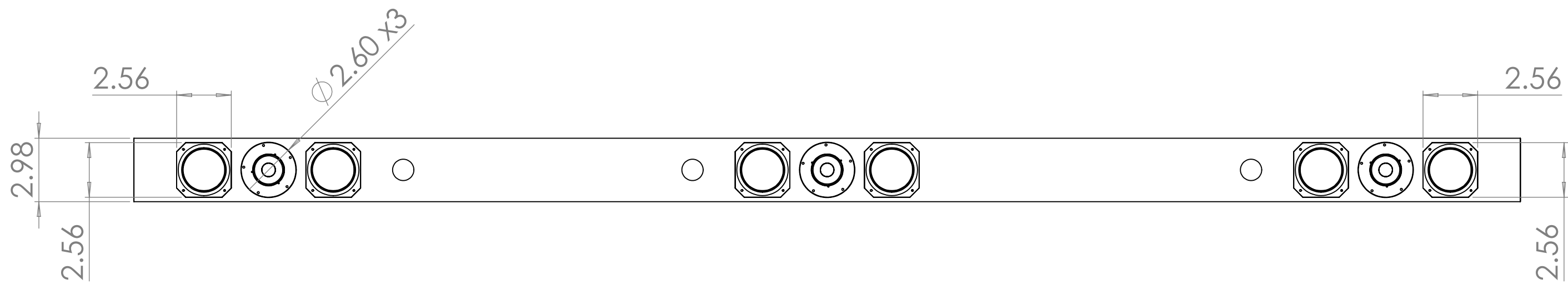
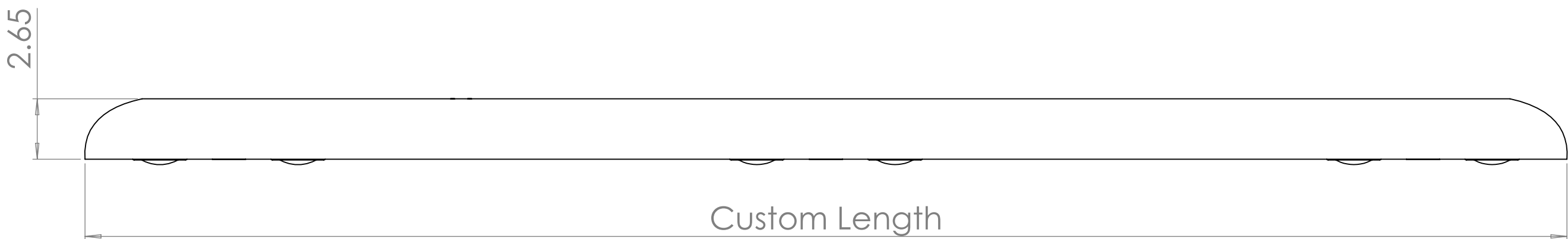
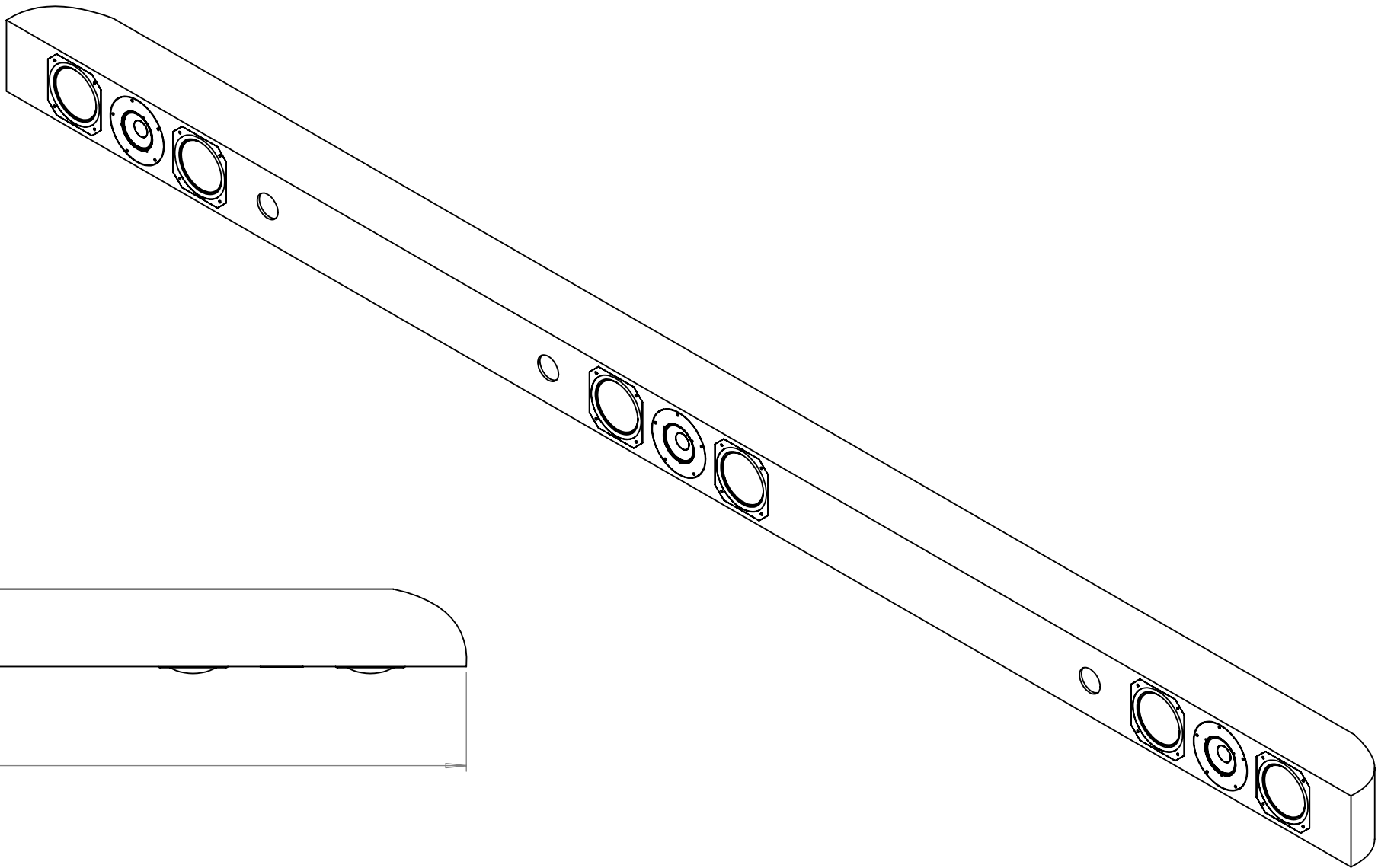

PROPRIETARY AND CONFIDENTIAL
 THE INFORMATION CONTAINED IN THIS DRAWING IS THE SOLE PROPERTY OF NEXT LEVEL ACOUSTICS. ANY REPRODUCTION IN PART OR AS A WHOLE WITHOUT THE WRITTEN PERMISSION OF NEXT LEVEL ACOUSTICS IS PROHIBITED.

UNLESS OTHERWISE SPECIFIED:		NAME	DATE	TITLE: Fusion S3 LCR
DIMENSIONS ARE IN INCHES		DRAWN		
TOLERANCES:		CHECKED		SIZE DWG. NO. REV C
FRACTIONAL \pm		ENG APPR.		
ANGULAR: MACH \pm BEND \pm		MFG APPR.		
TWO PLACE DECIMAL \pm		Q.A.		SCALE: 1:5 WEIGHT:
THREE PLACE DECIMAL \pm		COMMENTS:		
INTERPRET GEOMETRIC TOLERANCING PER:	MATERIAL			
FINISH	DO NOT SCALE DRAWING			
NEXT ASSY	USED ON			
APPLICATION				

4

3

2

1

D

D

C

C

B

B

A

A

4

3

2

1

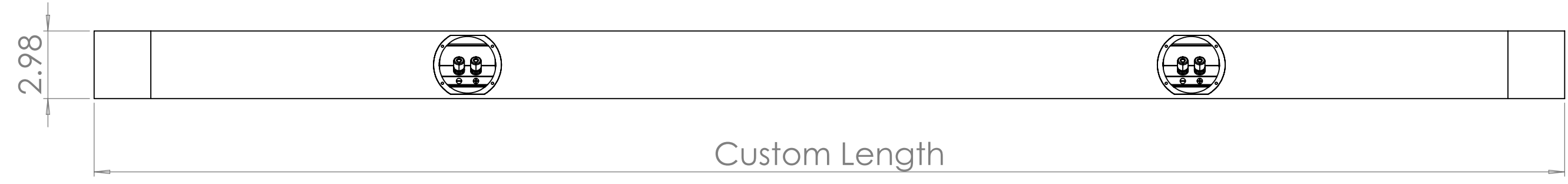
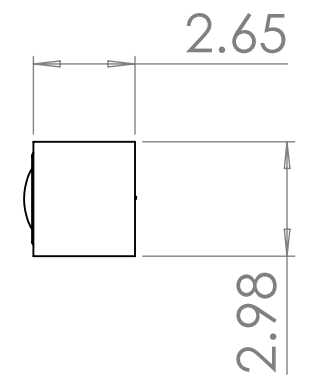
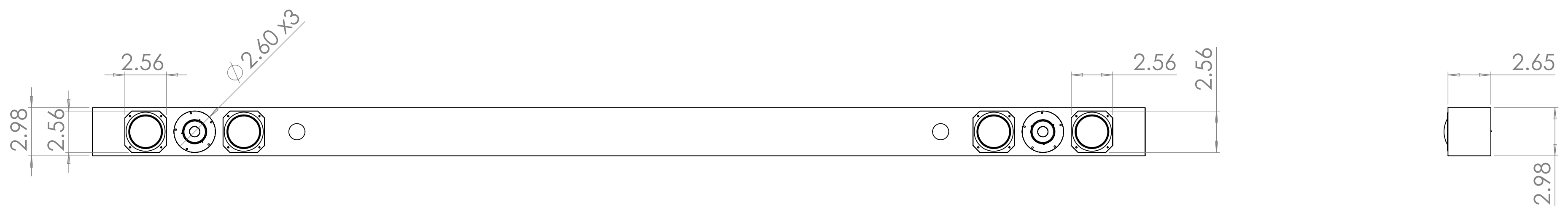
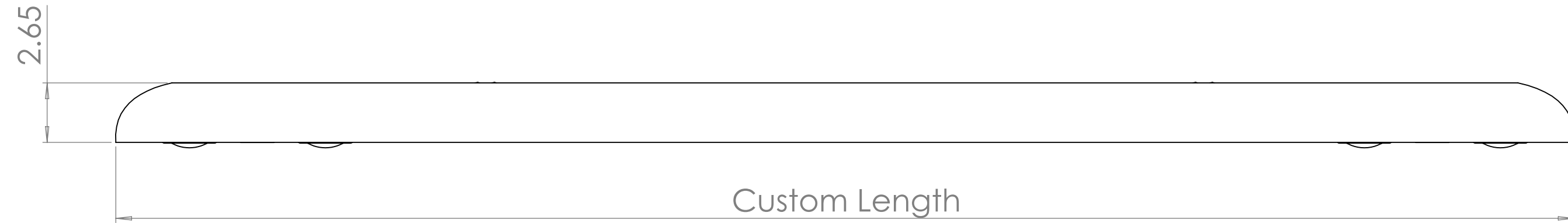
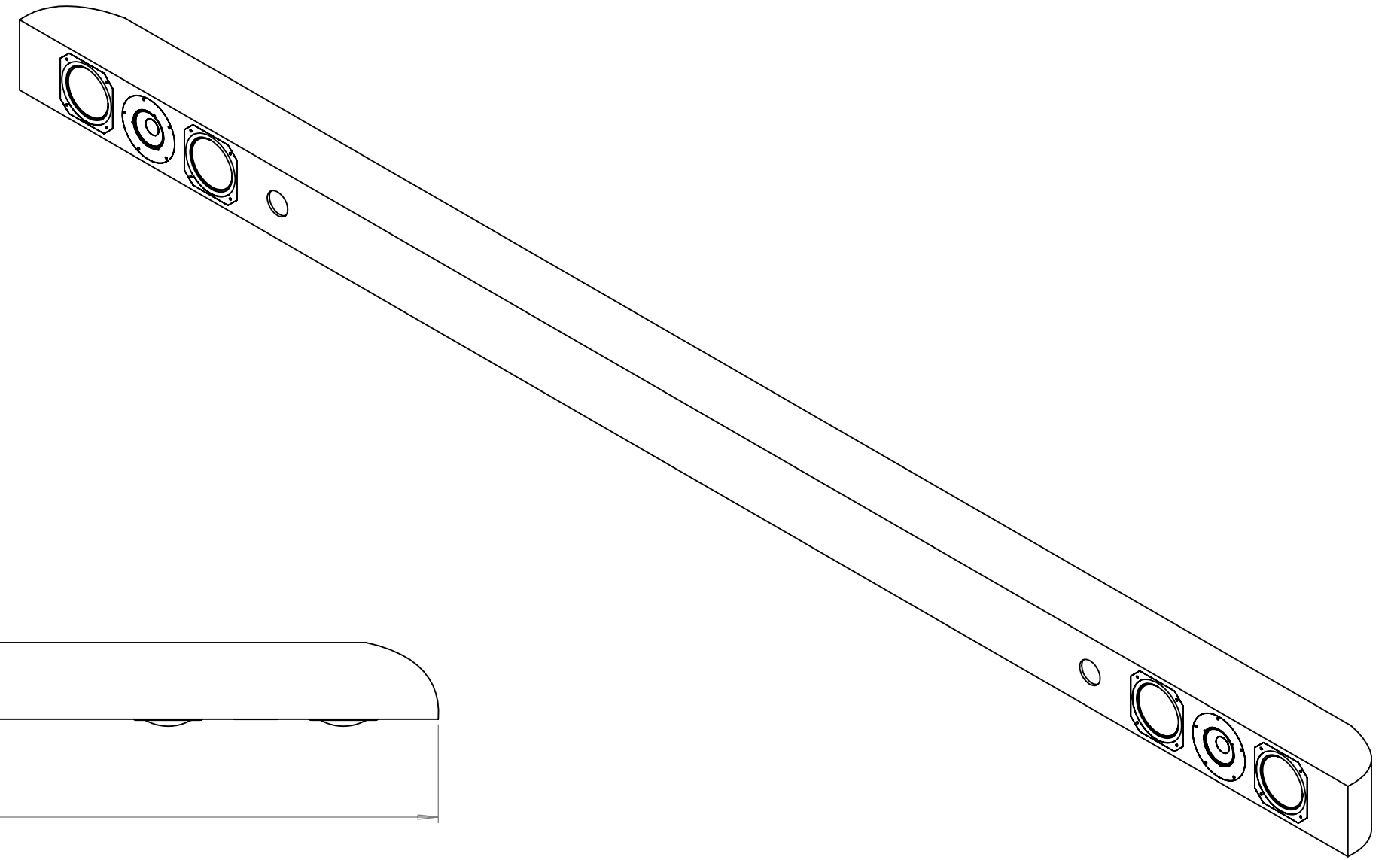

PROPRIETARY AND CONFIDENTIAL
 THE INFORMATION CONTAINED IN THIS DRAWING IS THE SOLE PROPERTY OF NEXT LEVEL ACOUSTICS. ANY REPRODUCTION IN PART OR AS A WHOLE WITHOUT THE WRITTEN PERMISSION OF NEXT LEVEL ACOUSTICS IS PROHIBITED.

		UNLESS OTHERWISE SPECIFIED:		NAME	DATE		
		DIMENSIONS ARE IN INCHES		DRAWN		TITLE:	
		TOLERANCES:		CHECKED		Fusion S3 Stereo	
		FRACTIONAL ±		ENG APPR.		SIZE DWG. NO. REV	
		ANGULAR: MACH ± BEND ±		MFG APPR.		C	
		TWO PLACE DECIMAL ±		Q.A.		SCALE: 1:5 WEIGHT:	
		THREE PLACE DECIMAL ±		COMMENTS:			
		INTERPRET GEOMETRIC TOLERANCING PER:					
		MATERIAL					
		FINISH					
NEXT ASSY	USED ON	APPLICATION					
		DO NOT SCALE DRAWING					

4

3

2

1

D

D

C

C

B

B

A

A