

WARRANTY - LIFETIME LIMITED

Next Level Acoustics will repair or replace any product found to be faulty due to defects in material or workmanship, with new or rebuilt parts, free of charge in the USA, from the date of original purchase, for the life of the product. This is a no-hassle warranty with no mail-in warranty card needed. This warranty does not cover damages in shipment, failures caused by other products, or failures due to accident, misuse, abuse, acts of God, or alteration of the equipment. This warranty is extended only to the original purchaser, when purchased through an authorized reseller and a purchase receipt, invoice, or other proof of original purchase date is provided. This warranty gives you specific legal rights and you may have other rights (which vary by area). If a problem with this product develops during or after the warranty period, please contact Next Level Acoustics, your dealer, or any factory-authorized service center for service. Mail-in service can be obtained during the warranty period by visiting NextLevelAcoustics.com. A Return Authorization (RA) number must be obtained in advance and a copy of the RA form should be included inside the shipping carton.

SUGGESTED SPEAKER LAYOUT OPTIONS

- A - Front Channel
- B - Center Channel
- C - Surround Channel
- D - Rear Surround Channel
- E - Subwoofer
- F - High-Resolution 2-Channel

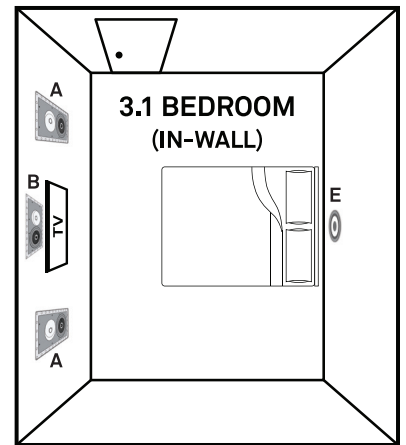
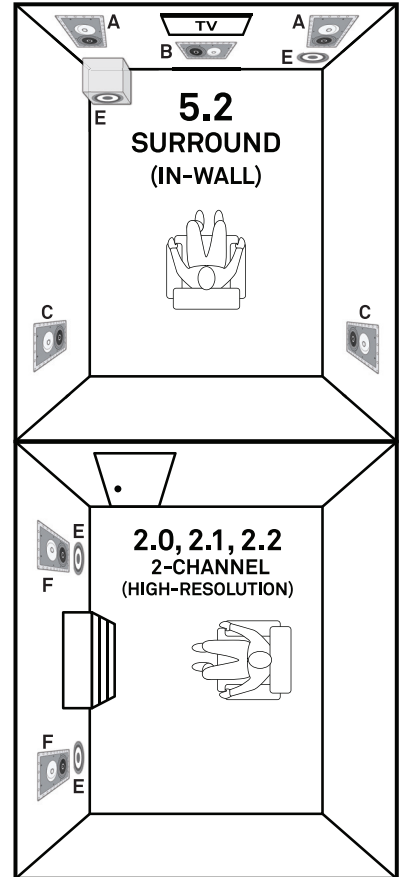

In-Wall model

Overall

Cut-Out (W x H x D)

CIB-IW6

6-1/2" In-Wall LCR Loudspeaker with Rotating Waveguide

9" x 15-3/4"

7-7/8" x 14-7/16" x 3-1/2"

Congratulations! You have purchased a high quality stereo loudspeaker. When matched to comparable electronic equipment, expect years of quality high fidelity sound. Our belief is that music matters and we are focused on delivering superlative music reproduction everywhere in your home.

The following manual is designed to give you, the installer or owner, basic information as to the speaker's installation and operation. It is beyond the scope of this manual to go into all the details that must be taken into consideration in a sophisticated high fidelity system. When installing the wiring and speakers it is important to adhere to all local codes and regulations. Consulting a professional can help to maximize your system's performance.

If you have any questions regarding this speaker which are not answered by this manual, contact your local dealer for assistance. For the most current information please visit TalonLoudspeaker.com.

SHIPPING DAMAGE

Each speaker is thoroughly tested before it leaves the factory. However, in shipment, accidents may occur. Please inspect your speakers carefully when you receive them to make sure there is no damage. If there is, please notify your dealer, or supplier immediately for assistance. If you received your speakers by public transportation, report the damage at once to the shipping company.

AMPLIFIER OPERATION

These speakers will perform well with amplifiers from 5 to 125 Watts RMS. However, damage to the speakers can be done by amplifiers of nearly any power rating if the amplifier is overdriven into clipping. "Amplifier clipping" is a phrase used to describe a condition when, because of the volume demand, an amplifier is being asked for more power than it can give. Clipping causes distortion of the audio signal. If you should hear an unusual amount of distortion at high listening levels then consider reducing the volume. **DAMAGE DONE TO A SPEAKER BY CLIPPING IS NOT COVERED UNDER THE WARRANTY.**

HOW IS THIS SPEAKER DIFFERENT?

This speaker was designed and engineered to provide the finest performance achievable in a compact package. The custom waveguide is unique in the industry and provides cross-axis performance that gives every listener in the room a sense of envelopment unmatched by other speakers in this category. By focusing the sound field across the listening space, the listener experiences a more balanced and symmetric sound level, especially when the main speakers are spaced more closely than is ideal, (common in many of today's home theaters).

The waveguide also increases the efficiency of the tweeter, allowing it to operate with far less input power and significantly lower distortion. This same waveguide also allows the tweeter to operate a full octave lower than conventional dome tweeters. This allows the tweeter to cover more of the critical voice range.

This same cross-axis tweeter design creates a much smoother off-axis listening experience, eliminating the midrange-hole that is commonly experienced with conventional designs. Additionally, by controlling the directivity of the sound field, the early reflections that occur from nearby walls and furniture are reduced so that more of the direct sound from the speakers are heard, improving the intelligibility and detail of the original sound source.

Finally, the inset tweeter produces a time aligned position and excellent phase coherency with the woofer, improving the off-axis performance, both in the vertical and horizontal directions.

SOME OF THE WAYS THIS SPEAKER CAN BE USED

This speaker can be used for 2-channel High Resolution audio or for nearly any speaker location within a home theater system. The following chart provides suggested tweeter orientations for a number of common speaker locations within a home theater. We encourage you to experiment with the tweeter orientation to see what works best within your system, especially with surround placements.

While it may seem unconventional to use this speaker in the Landscape orientation for the center dialog speaker, it is actually well suited because of the excellent phase coherency between the tweeter and woofer. The speaker actually outperforms most of MTM (Mid-Tweeter-Mid) designs that have become commonplace for the center dialog channel.

ROTATING THE TWEETER

- The tweeter should be rotated into the desired position for optimal performance.
- There are detents every 15 degrees. The tweeter will lock into these detents when positioned over them.
- Press firmly at the edge of the tweeter waveguide using 4 fingers.
- A gap of about 2mm will appear at the edge when depressed.
- Rotate the tweeter into the desired position, releasing when you feel a detent.



- NOTE: It may be necessary to moisten one's fingers to achieve good traction on the waveguide.
- The detents will not be felt when the waveguide is fully depressed. Decrease pressure to locate the detents.

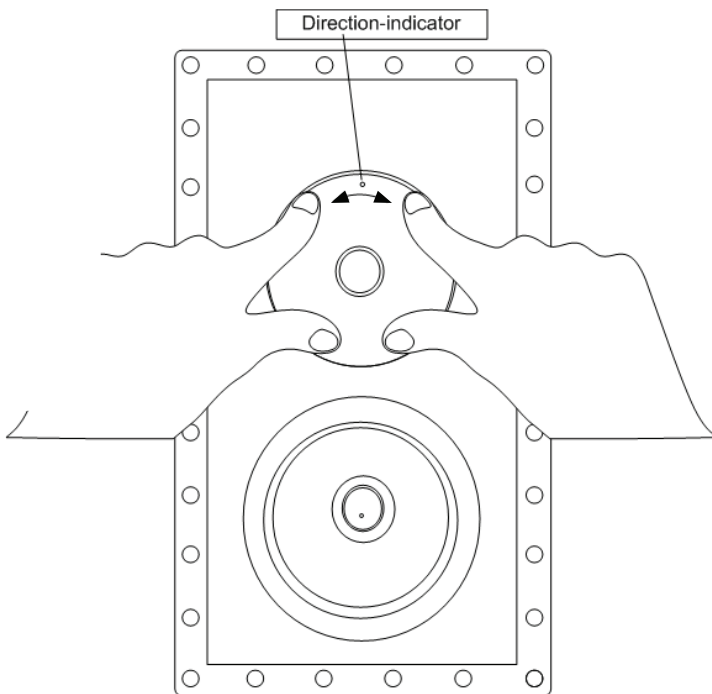

LOCKING THE TWEETER INTO PLACE

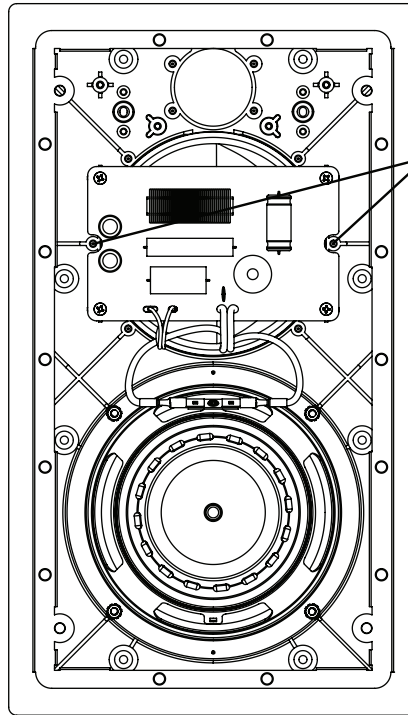

Optional Security Hole
Two holes have been provided to lock the tweeter into place and prevent rotation. Should it be desirable to lock the tweeter, install two #6x3/8" (3.5mm X 10mm) sheet metal screws with flat washers in the provided holes. (Hardware not included)

SPEAKER PLACEMENT

If after reading this Installation Guide you are uncomfortable with the planning or installation process then please contact a professional for assistance. Placement of In-wall speakers should be carefully considered and it is beyond the scope of this publication to discuss all of the various aspects of speaker placement but here are some helpful suggestions.

Ideally, the speakers should be located where they will provide the best possible sound and ease of installation. When used in a home theater or 2-channel high resolution audio system, the front left and right speakers should be ear level, or a little higher, and separated from each other a distance of 0.75x to 1x the seating distance. For example, if the seating position is 10 feet from the wall where the speakers are to be installed, then ideally the distance between the left and right speakers should be somewhere between 7.5 and 10 feet, (Ex. 0.75 x 10ft = 7.5ft). If the speakers are located behind an acoustically transparent screen then all the speakers should be oriented portrait style. The tweeter should be aimed toward the listening area. For other tweeter positions see the tweeter positions chart to the left.

Placing the speakers within 18 to 36 inches of an adjacent wall, as measured to the center of the speaker, will tend to increase the effective bass output. Avoid placing the speakers less than 18 inches from an adjacent wall. When placing speakers near a corner, avoid locating them an equal distance from the two adjacent surfaces.

WIRING

To achieve maximum performance we recommend that the speaker cable be at least 16 gauge or larger for runs over 50 feet (15m) and that the cable be double insulated. A CL-2 or CL-3 rated cable may be required. Check local codes. "Zip cord," which is single insulated and is often made with clear insulation, should be

Tweeter Positions for Common Speaker Locations

 Left Front Speaker At Ear Level	 Center Speaker Below Ear Level	 Right Front Speaker At Ear Level
 Left Front Speaker Above Ear Level	 Center Speaker Above Ear Level	 Right Front Speaker Above Ear Level
 Surround Reflecting off Ceiling (Diffused Sound Field)	 Surround Directed Toward Seating	 Surround Reflecting off Wall (Diffused Sound Field)

avoided as it is not as durable. Allow about 2½ feet (0.8m) of free cable at the speaker cut-out and sufficient length at the other end to reach the electronics. Having to add extra cable later can be tedious and time consuming.

Avoid bundling speaker cables parallel to electrical cables for extended lengths. Though the impedance is low and the likelihood of interference low, this may help reduce hum and RF interference. When securing the cable, use care not to staple or nail through the electrical conductors. Doing so could result in a short that might damage the electronics.

When connecting your speakers, make sure proper polarity (phasing) is maintained. Simply put, this means ensuring the same wire which is connected to the positive terminal of the amplifier has its other end connected to the positive terminal of the speaker. It is important to check this on all speakers. If the connections on one of the speakers are reversed, (out of phase) the sound quality will be impaired.

INSTALLATION

If the drywall is installed and the speaker locations have not yet been established, then do so now. Assess the wall for possible concealed obstructions such as wiring, plumbing, etc. Inspect the backside of the wall, the attic, and/or the crawl space if available for clues to possible obstructions. Use inspection tools (camera, mirror, flashlight, etc.) if absolutely necessary. Use a “stud finder” to locate the positions of the studs.

The CIB-IW6 is shipped with a Clamp Ring (A). With this clamp ring, the edge of the speaker opening must be at least 1/2" (13mm) away from a stud if the speaker is installed in the portrait orientation. If mounting closer to the stud when in the portrait orientation, an additional clamp ring (B) is sold separately.

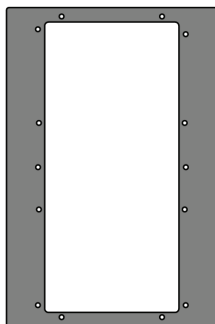

Once the speaker locations are established use the cardboard template (the outside of the inner cardboard rectangle) to mark the speaker cut-out. The dimensions for the cut-out are listed in the chart on the previous page. Using the proper tool, cut the appropriate sized hole in the wall. On drywall, clean cuts can be made with a drywall saw. Cut-out dimensions are included on the 1st page.

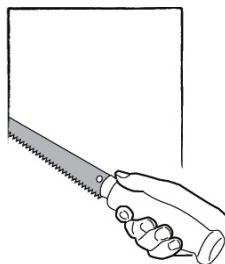

If the cable has not yet been run, do so now that you have access to the wall's interior.

To aid in speaker performance, a fibrous material, such as fiberglass, may be placed behind the speaker. This may also help to reduce unwanted sound from being transmitted into adjoining rooms. If the wall space has blown or loose insulation, care must be taken to prevent the loose insulation from entering the back of the speaker. This can be accomplished by placing a batt of fiberglass insulation behind the back of the speaker.

Install the frame and clamp ring assembly by passing the metal clamp ring through the cut-out as illustrated in **figures 1 & 2 to the right**. The frame should fit cleanly, without interference, in the cut-out hole. If the hole is a little small then trim the hole as needed. Lightly tighten the screws to secure the clamp ring against the back of the wall (**see fig. 3**). Use care not to over-tighten the screws or the frame may become distorted. **Note: Use only the 4 outer holes for mounting the frame.**

Pull the end of the cable out of the wall, strip back a section of the jacket as needed, and then expose ½" (13mm) of each conductor. Connect the wire to the terminals on the back of the speaker assembly, observing polarity (+ & -).

Insert the speaker into the frame and install the eight screws (**see fig. 4**).

PAINTING THE GRILLE

The grilles can be painted using multiple light coats of spray paint. Custom color spray paints are available from specialty companies. Contact your dealer for more information. The grilles should be removed from the speaker and painted in a clean environment to prevent contamination. It is best to go around the grilles and apply the paint from multiple angles. **DO NOT** remove the scrim cloth from the backside of the grille. It is not replaceable.

Attach the grilles to the speakers and enjoy. Should you wish to remove the grilles from the speakers pull at the grilles' corners. Initially there will be significant resistance because the grilles are magnetically attached.

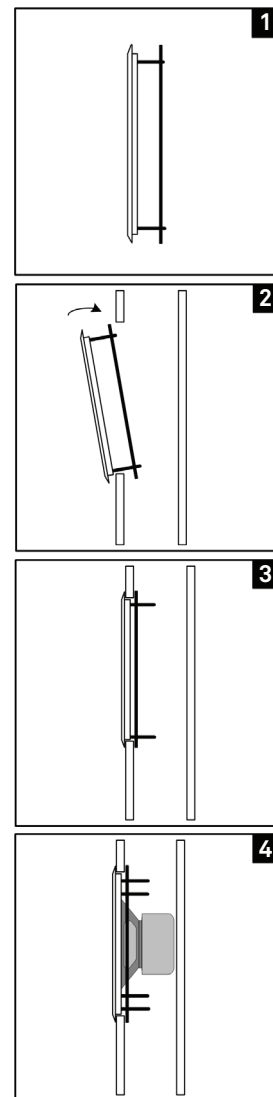

Speaker Installation
As Viewed from Above